

ERG-SR

PRESSURE REGULATOR

ERG-SR

ERG-SR Series pressure regulator is used on gas line to reduce inlet pressure to desired outlet pressure. It is suitable for both commercial and residential usage where can be directly installed to gas meters with high operational reliability and accurate outlet pressure accuracy.

Simple installation procedure. Direction of the line can be inline or angle.

Due to different inlet and outlet connection range, ERG-SR Series can be used along with pipe diameter from DN20 to DN50 with different thread standards as well as BSP, BSPT, NPT, NPP. (Also, can be added to "angle" connection.)

The regulators are manufactured according to PED Directive 2014/68/EC. The performance of the regulators complies with EN334.

Features

- For medium pressure domestic or commercial second group gas lines.
- Optional metallic mesh filter for easy change and guarantees longer operation life of regulator.
- Outlet pressure tolerance is +%10 (AC10) up + %5 (AC5)
- Lock-up pressure tolerance is +%20 (SG20) up to 100 mbar outlet pressure, more than 100 mbar outlet pressure SG20 and SG10 possible.
- Up to 6 bar inlet pressure.
- 15 - 360 mbar outlet pressure range with interchangeable springs
- OPSO pressure range 35 - 520 mbar
- UPSO pressure range 8 - 250 mbar

Configurations

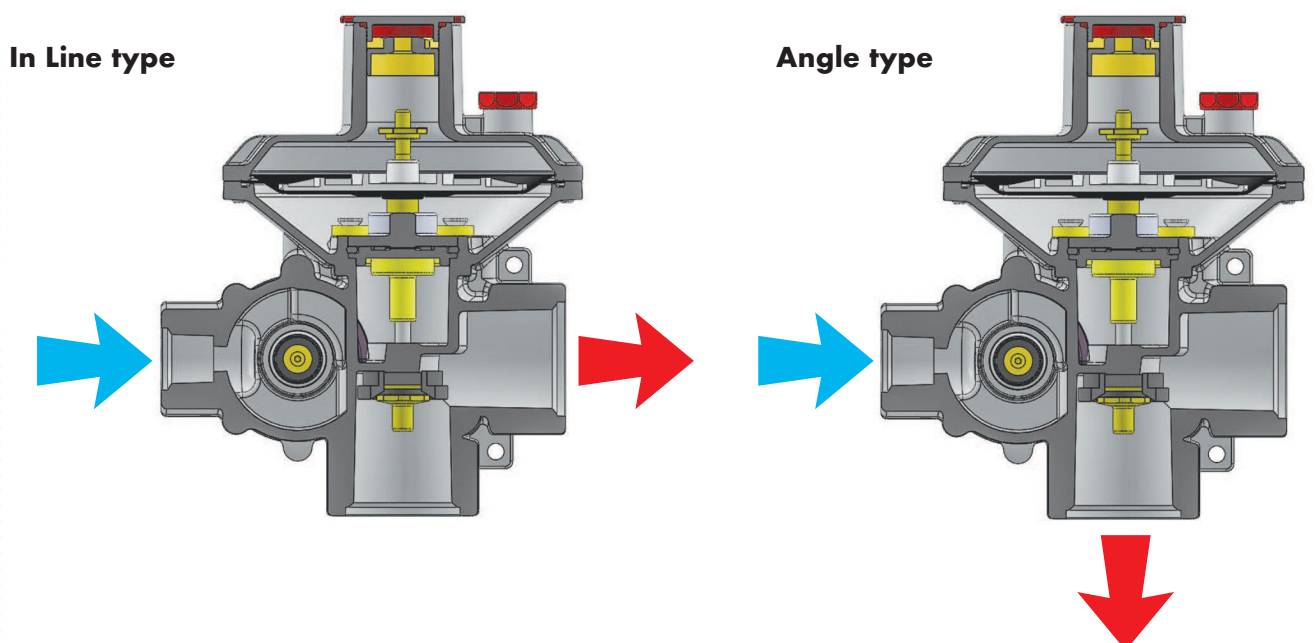

Dimensions

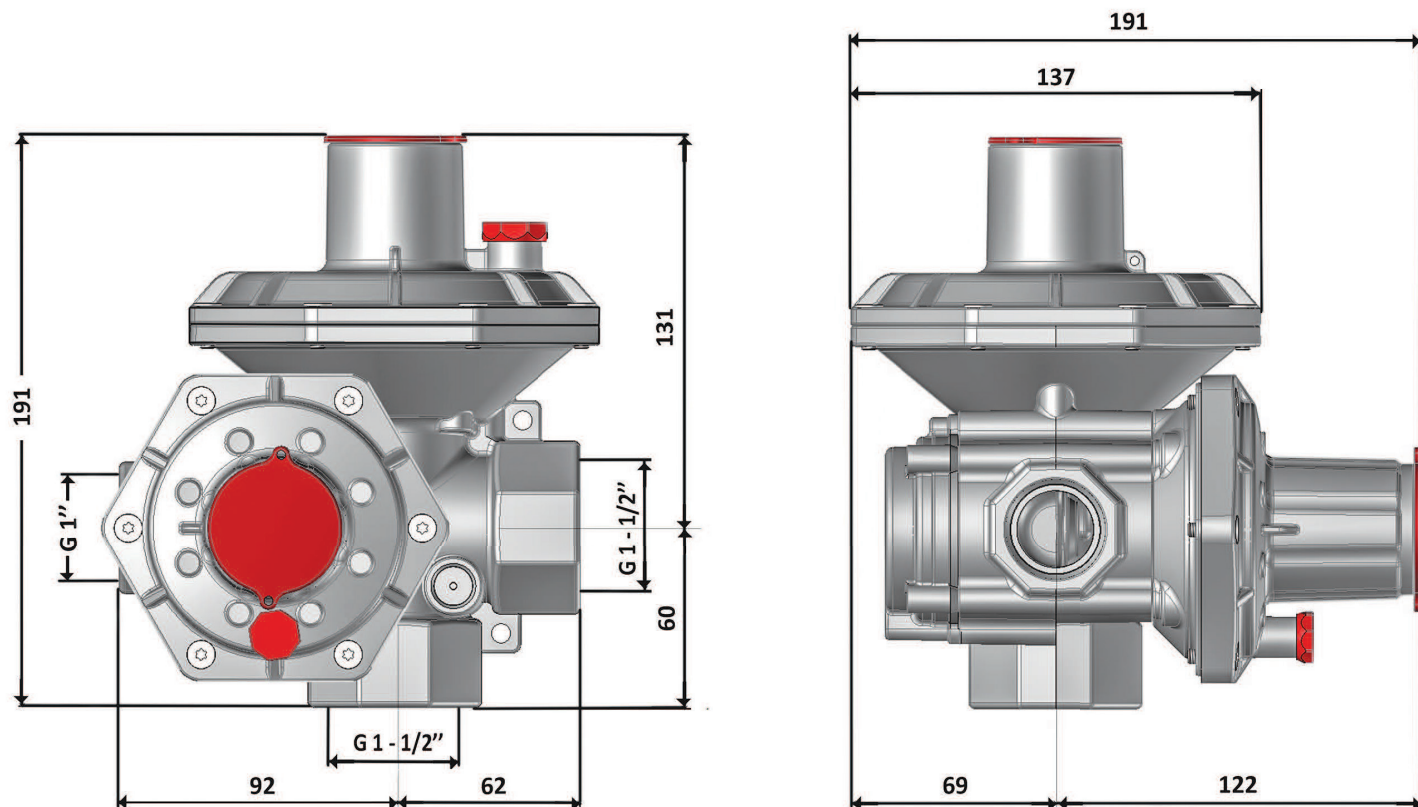

Connections types

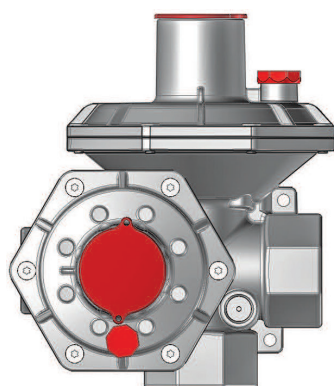

Without Connection

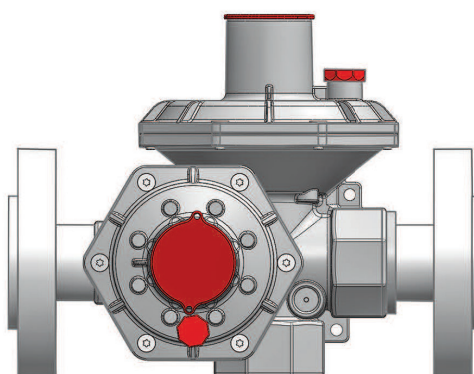

With Flanged Connection

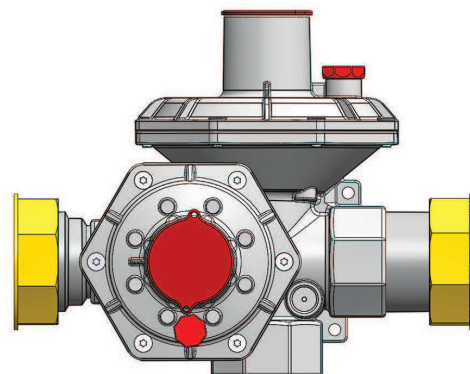

With Loose Connection

SAFETY AND ACCESSORIES Relief System

Relief System

- Regulator can be produced with a relief valve. Relief valve monitors outlet pressure continuously and when it detects pressure level higher than regulator's nominal outlet pressure, it activates and discharges gas to the atmosphere.
- Relief valve has limited discharge capacity. Usually calibration point is lower than OPSO system. Under certain conditions such as gas expansion during hot weather seasons, Relief valve is activated before OPSO closes the gas lines. It prevents random shut-off regarding pressure increase on outlet side.
- Relief valve can be recalibrated by using proper tools.

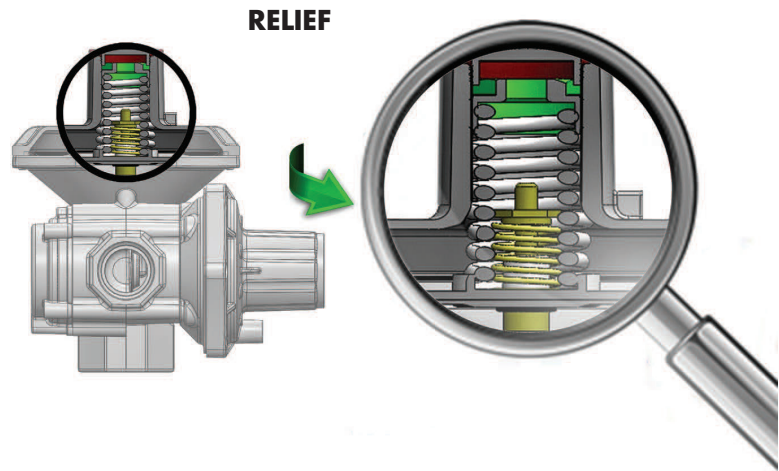

Over Pressure Shut-Off System

- OPSO system is very useful during major breakdown situations and keeps the customer side safe. System works as a security valve and activates itself when the outlet pressure passes OPSO calibration point. OPSO system cuts the gas off, and manual reset is needed to activate the regulator again.
- System has an independent shut-off mechanism and orifice and it monitors outlet pressure changes continuously, so the activation time is below 2 seconds.

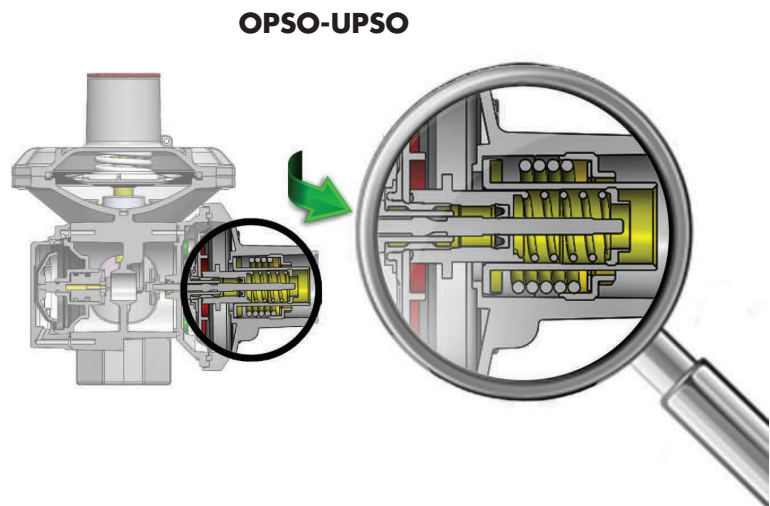

Under Pressure Shut-Off System.

- UPSO system on SR series regulator is pressure based. It cuts the gas off when the outlet pressure drops below the UPSO calibration point.
- UPSO valve continuously monitors outlet pressure changes. Scenarios like, pipeline breakdown on outlet sides, or consumption is exceeding the total capacity of regulator or lack of inlet pressure situations etc...the outlet pressure drops and the regulator cuts the gas off once UPSO system is activated.

Specifications

Fluid :	Natural Gas, LPG and Non-Corrosive Gases
Operating temperature :	-20... + 60 °C (optional : -40... +60 °C)
Assembly :	Vertical and Horizontal Position
Maximum inlet pressure :	6 bar
Outlet pressure range:	15 to 360 mbar.
Referring:	PED 2014/68/EU
Filter :	As a standard 100 micron pore diameter.

Design

The ERG-SR Series pressure regulator body consists of:

- Valve housing PS6
- Loose nut or body thread or angled connection
- Filter
- Ventilation console
- Outlet pressure test point
- Integrated security valves

Materials

- Body and covers Aluminum according to EN1706 standard.
- Rubber components comply with to EN549.
- Brass materials comply with EN12164 Standard.
- Filter material is metallic mesh lter.

MODEL	NOMINAL CAPACITY	REQUIRED MINIMUM INLET PRESSURE BAR (PSI)
ERG-SR 50	50 STM3/H	OUTLET PRESSURE + 0.5
ERG-SR 75	75 STM3/H	OUTLET PRESSURE + 0.5
ERG-SR 100	100 STM3/H	OUTLET PRESSURE + 0.5

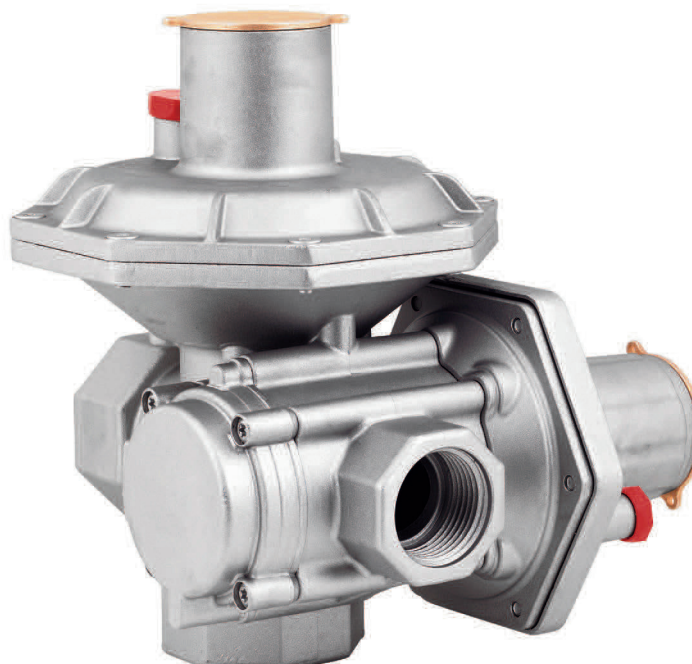

Product range



Rotary piston gas meters



Turbine gas meters



Gas pressure regulators



Electronic volume correctors



Diaphragm gas meters



Smart meters

metrixitalia

Metrix Italia s.r.l.

Via Nona Strada 53 - 35129 Padova (Italy)

Tel: +39 049 5349377 - Fax: +39 049 8076008

www.metrixitalia.it - E-mail: info@metrixitalia.it